

Queue cône Morse
Morse taper shank
Mango
Cono Morse

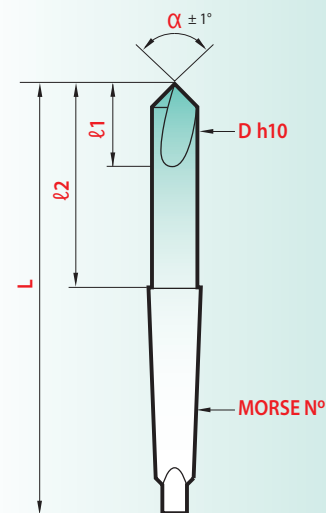

D h10	L ±1	ℓ1 +1	ℓ2 +1	MORSE N°	90°		120°	
					magafor 198	€	magafor 1906	€
10,0	130	25	64	1	88,30	€	102,93	€
12,0	130	30	64	1	92,48		127,49	
16,0	148	35	68	2	113,90		151,52	
20,0	148	40	68	2	135,85		206,91	
25,0	171	45	72	3	187,05			

magafor



OUTILS MULTI-FONCTIONS
MULTI-FUNCTION TOOLS
HERRAMIENTAS MULTI-FUNCIÓN
UTENSILI MULTI-FUNZIONE

Promo-kits



6 COMBI-mag Ø 4 - 5 - 6 - 8 - 10 - 12
007 €143,16



90°

COMBI-mag

inch	D h7 mm	L ±1	ℓ +1	T*	Red'X 007
	3	50	6	0,3	€ 16,20
1/8"	3,17	50	6	0,3	16,20
	4	52	8	0,4	16,72
3/16"	4,76	60	9	0,5	17,24
	5	60	10	0,5	17,24
	6	66	12	0,6	20,38
1/4"	6,35	66	12	0,6	21,42
	7,93	79	14	0,8	23,77
	8	79	14	0,8	23,77
3/8"	9,52	89	16	1	27,17
	10	89	16	1	28,21
	12	102	18	1,2	36,57
1/2"	12,7	102	19	1,3	38,66
	14	115	21	1,4	51,73
5/8"	15,87	115	24	1,6	53,82
	16	115	24	1,6	53,82

*T = 0,1 D Épaisseur d'âme Web thickness Espesor del núcleo Spessore in punta del nocciolo

COMBI-mag

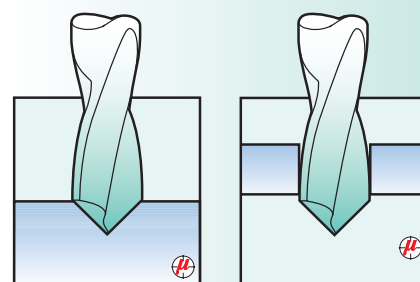

POINTAGE
 SPOTTING
 PUNTEADO
 CENTRATURA

PERÇAGE
 DRILLING
 TALADRADO
 FORATURA

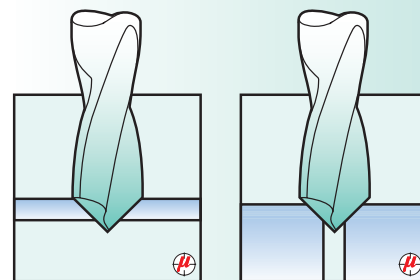

CHANFREIN DIRECT
 DIRECT CHAMFER
 CHAFLANES DIRECTOS
 SVASATURA RAPIDA

CHANFREINAGE
 COUNTERSINKING
 AVELLANADO
 SMUSSATURA

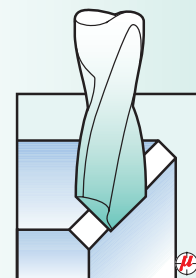

CHANFREIN LONGITUDINAL
 LONGITUDINAL CHAMFER
 CHAFLANES LONGITUDINALES
 SMUSSI LONGITUDINALI