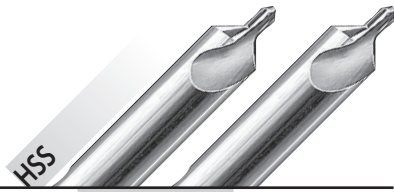
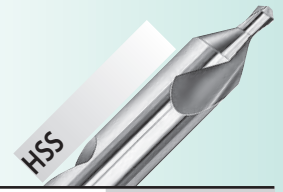

**82°-90°****60°**

ASA N°	D x d		L ± 1v	ℓ		82°	90°
	h7	k12		mini	maxi	154	155
1	3,17 x 1,19 (1/8 x 3/64)		31	1,4 ~ 1,7		€ 12,28	€ 12,28
2	4,76 x 1,98 (3/16 x 5/64)		47	2,4 ~ 2,7		11,76	11,76
3	6,35 x 2,77 (1/4 x 7/64)		50	3,3 ~ 3,9		14,11	14,11
4	7,93 x 3,17 (5/16 x 1/8)		54	3,8 ~ 4,4		16,46	16,46
5	11,11 x 4,76 (7/16 x 3/16)		70	5,9 ~ 6,5		31,35	31,35
6	12,70 x 5,55 (1/2 x 7/32)		76	6,9 ~ 7,5		34,48	34,48
7	15,87 x 6,35 (5/8 x 1/4)		82	8,0 ~ 8,6		56,95	56,95
8	19,05 x 7,93 (3/4 x 5/16)		89	10,0 ~ 10,6		72,10	72,10

BS N°	D x d		L ± 1	ℓ		magafor
	h7	k12		mini	maxi	114
1	3,17 x 1,19 (1/8 x 3/64)		38	1,5 ~ 1,8		€ 5,12
2	4,76 x 1,58 (3/16 x 1/16)		44	2,0 ~ 2,4		5,33
3	6,35 x 2,38 (1/4 x 3/32)		50	3,3 ~ 3,9		6,17
4	7,93 x 3,17 (5/16 x 1/8)		56	4,1 ~ 4,7		7,11
5	11,11 x 4,76 (7/16 x 3/16)		63	6,5 ~ 7,1		12,80
6	15,87 x 6,35 (5/8 x 1/4)		75	8,5 ~ 9,1		22,21
7	19,05 x 7,93 (3/4 x 5/16)		89	10,8 ~ 11,6		40,75

Longs Largas Serie Lunga

**60°-82°-90°**

ASA N°	D x d		L ± 1	60°	60°	82°	90°
	h7	k12		185	186	154-L	155-L
1 x 3"			76	€ 9,72	€ 12,15	€ 17,24	€ 17,24
1 x 4"	3,17 x 1,19		102	18,29	22,86	32,39	32,39
1 x 5"	(1/8 x 3/64)		127	24,30	30,37	42,84	42,84
1 x 6"			152	27,17	33,96	47,02	47,02
2 x 3"			76	10,45	13,06	18,29	18,29
2 x 4"	4,76 x 1,98		102	16,98	21,22	29,78	29,78
2 x 5"	(3/16 x 5/64)		127	23,51	29,39	41,28	41,28
2 x 6"			152	26,65	33,13	48,07	48,07
3 x 3"			76	10,71			
3 x 4"	6,35 x 2,77		102	16,98	21,22	30,30	30,30
3 x 5"	(1/4 x 7/64)		127	23,77	29,39	43,89	43,89
3 x 6"			152	26,65	33,13	49,64	49,64
4 x 3"			76	11,23			
4 x 4"	7,93 x 3,17		102	17,77	22,21	31,35	31,35
4 x 5"	(5/16 x 1/8)		127	27,69	34,61	49,64	49,64
4 x 6"			152	30,83	38,54	54,34	54,34
4-1/2 x 4"			102	18,81			
4-1/2 x 5"	9,52 x 3,57		127	31,87			
4-1/2 x 6"	(3/8 x 9/64)		152	36,05	45,06	65,31	65,31
5 x 4"			102	23,77	29,71	41,80	41,80
5 x 5"	11,11 x 4,76		127	38,66	48,33	67,92	67,92
5 x 6"	(7/16 x 3/16)		152	42,84	53,55	75,24	75,24
6 x 4"			102	24,30	30,38	44,41	44,41
6 x 5"	12,70 x 5,55		127	39,19	48,99	70,54	70,54
6 x 6"	(1/2 x 7/32)		152	43,89	54,86	78,38	78,38
7 x 5"	15,87 x 6,35		127	49,64			
7 x 6"	(5/8 x 1/4)		152	57,47	71,83	88,82	88,82
8 x 6"	19,05 x 7,93 (3/4 x 5/16)		152	63,74	79,68	114,95	114,95

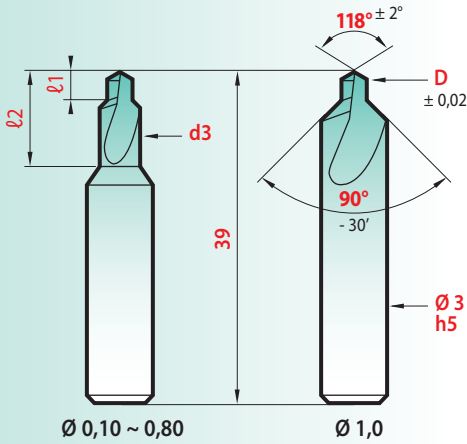
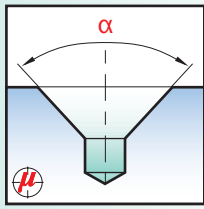

FORETS À CENTRER 90°

90° CENTER DRILLS

BROCAS DE CENTRAR 90°

PUNTE A CENTRARE 90°

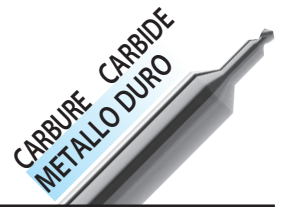
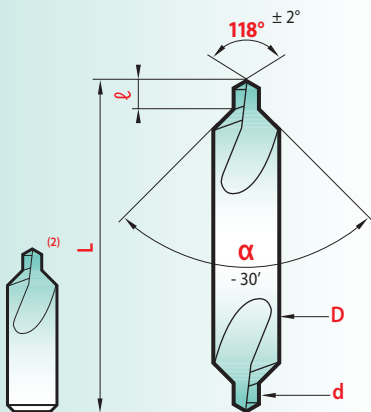

D	d3 mini	l1 mini	l2	magaforce 82X1
0,10	0,55	0,10	1,8	€ 33,96
0,15	0,55	0,15	1,8	33,44
0,20	0,55	0,20	1,8	32,92
0,25	0,85	0,25	2,7	32,39
0,30	0,85	0,30	2,7	31,35
0,40	1,4	0,40	4,5	30,30
0,50	1,4	0,50	4,5	30,30
0,60	2,3	0,60	7,2	30,30
0,80	2,3	0,80	7,2	30,30
1,00	-	1,00	-	30,30

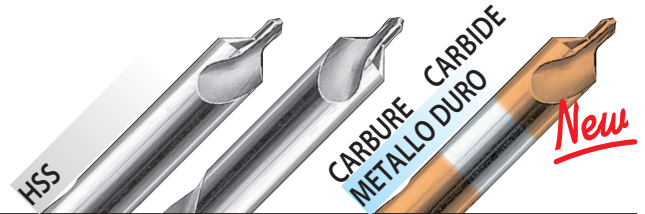

TYPE
TIPO

D x d h7 ⁽¹⁾ k12	L ± 1	l mini maxi	magafor 15	magafor 175	Hard'X 8115-H
3,0 x 0,5 ⁽²⁾	25	0,6 ~ 0,9	€ 13,32	€	€
3,5 x 0,75	35	1,0 ~ 1,3	12,02		
4,0 x 1,0	35	1,3 ~ 1,7	10,97	35,01	65,31
5,0 x 1,5	40	2,0 ~ 2,6	11,23	37,62	
6,0 x 2,0	45	2,5 ~ 3,1	13,85	39,71	91,44
8,0 x 2,5	50	3,1 ~ 3,8	15,94	42,32	
8,0 x 3,0	50	3,9 ~ 4,6	15,94	42,32	112,34
10,0 x 3,0	55	3,9 ~ 4,6	20,64	48,59	
10,0 x 4,0	55	5,0 ~ 5,9	20,64	48,59	146,30
12,0 x 4,0	63	5,0 ~ 5,9	31,35		
12,0 x 5,0	63	6,3 ~ 7,2	31,35		
14,0 x 5,0	69	6,3 ~ 7,2	43,37		
18,0 x 6,0	77	8,0 ~ 8,9	63,74		
25,0 x 8,0	100	10,1 ~ 11,1	136,89		

⁽¹⁾ CARBURE CARBIDE METAL DURO METALLO DURO = h5

⁽²⁾ 1 côté Single end De una sola punta Ad un solo lato

Longs Largas Serie Lunga

HSS-E COBALT

D x d h7 k12	L ± 1	l mini maxi	magafor 188
4,0 x 1,0	120	1,3 ~ 1,7	€ 70,02
5,0 x 1,5	120	2,0 ~ 2,6	65,83
6,0 x 1,0	80	0,7 ~ 1,0	41,80
6,0 x 2,0	120	2,5 ~ 3,1	65,83
8,0 x 2,5	120	3,1 ~ 3,8	72,25
10,0 x 2,0	100	1,0 ~ 1,4	55,38
10,0 x 3,0	120	3,9 ~ 4,6	79,87
10,0 x 4,0	120	5,0 ~ 5,9	79,87
16,0 x 3,0	120	1,8 ~ 2,3	110,77