

MULTI-DIA

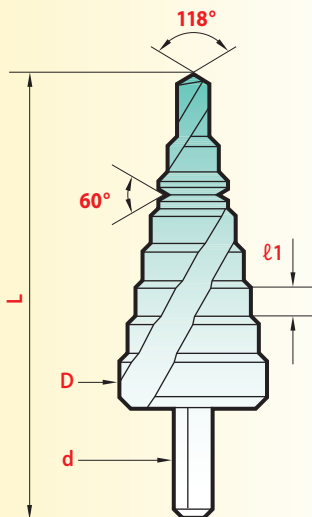

90°
MULTI-DIA

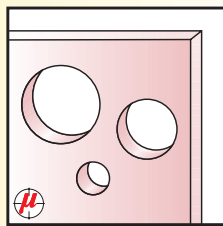
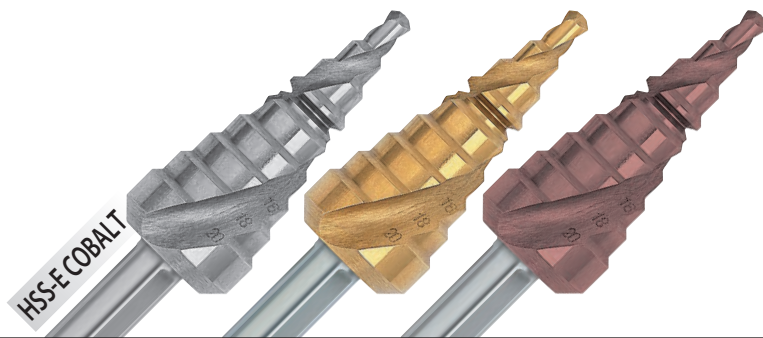

D	Capacité Capacidad	Capacity Capacità	L	ℓ1	d	MULTI-DIA 275	TiN 2875	Red'X 2975
12	4-5-6-7-8-9-10-11-12		79	5	6	€ 22,21	€ 25,60	€ 26,90
20	4-6-8-10-12-14-16-18-20		67	3	8	37,10	43,37	45,55
30	4-6-8-10-12-14-16-18 20-22-24-26-28-30		100	4	10	75,76	84,12	88,30
32,5*	5-7,5-9,7-12,7-15,2-16,2-18,6 20,4-22,5-25,4-28,3-30,5-32,5		78	4	10	94,05	103,98	109,15
38	6-9-13-16-19-21-23 26-29-32-35-38		100	4	10	112,34	124,88	131,10

* Spécial électriciens (Presse-étoupe) PG 7 ~ 21
Especial electricistas (broqueros) PG 7 ~ 21

Special electricians (Stuffing box) PG 7 ~ 21
Specifico per elettricisti (Premistoppa) PG 7 ~ 21

FORET MULTI-ÉTAGES Goujures HÉLICOÏDALES

MULTI-STEPS DRILLS SPIRAL flutes

BROCAS ESCALONADAS Labios HELICOIDALES

UTENSILI CONICI A GRADINI Scanalature ELICOIDALI



Promo-kits

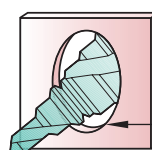

Ébavure
Deburrs
Desbarbado
Sbavatura

HSS 5% COBALT
Revêtement TiN = durée de vie prolongée
TiN coating = extended tool life
Recubrimiento TiN = larga duración de herramienta
Rivestimento TiN = maggior durata dell'utensile

Diamètres marqués
Marked diameters
Diámetros marcados
Indicazione dei diametri

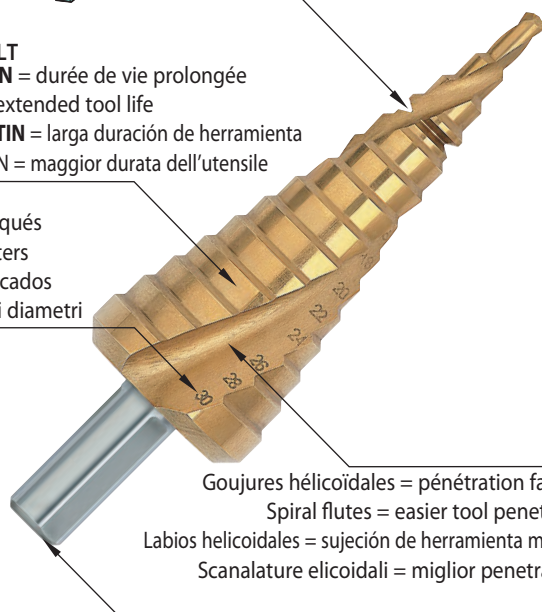

Goujures hélicoïdales = pénétration facilitée
Spiral flutes = easier tool penetration
Labios helicoidales = sujeción de herramienta más fácil
Scanalature elicoidali = miglior penetrazione



Queue 3 plats = meilleur serrage
3 flated shanks = better holding
Mango con 3 piani = mejor sujeción
Codolo con 3 piani = bloccaggio rapido ed efficace

3 MULTI-DIA Ø 12 - 20 - 30

Code **275** € 135,07

Code **2875** € 153,09

Code **2975** € 160,74

MULTI-DIA

90°
MULTI-DIA

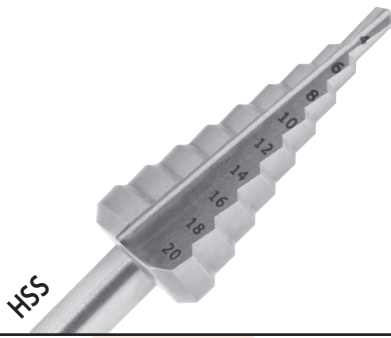

D	Capacité Capacidad Capacità	L	ℓ1	d	Classic 273
12	4-5-6-7-8-9-10-11-12	79	5	6	€ 17,50
20	4-6-8-10-12-14-16-18-20	67	3	8	30,57
30	4-6-8-10-12-14-16-18 20-22-24-26-28-30	100	4	10	60,09
38	6-9-13-16-19-21-23 26-29-32-35-38	100	4	10	91,44

MULTI-DIA



Forets conçus pour le perçage de tôles et matériaux en feuilles jusqu'à une épaisseur de 3 mm et pour tubes fins, épaisseur 3 mm maxi. Un seul outil remplace de nombreux forets classiques. Queue avec 3 plats pour assurer un serrage efficace.

Drills designed for sheets or thin materials up-to 3 mm thickness and for tubes up-to 3 mm. One tool will replace several twist drills. Shanks with 3 flats for better holding.

Brocas diseñadas para taladrado de chapa o láminas de hasta 3 mm de espesor y para tubos de espesor hasta 3 mm. Una sola herramienta reemplaza varias brocas clásicas. Mangos con 3 planos para una mejor sujeción.

Utensili concepiti per la foratura di lamiera e di laminati fino ad uno spessore di 3 mm e per tubi aventi spessore massimo di 3 mm. Un solo utensile è in grado di sostituire numerose punte elicoidali. Codolo con 3 piani per assicurare un bloccaggio efficace.

QUEUES SHANK MANGO CODOLO HEXAGONALES

6,35
1/4"



90°
MULTI-DIA

D	Capacité Capacidad Capacità	L	ℓ1	Classic 276
12	4-5-6-7-8-9-10-11-12	79	5	€ 19,50
20	4-6-8-10-12-14-16-18-20	67	3	33,75
30	4-6-8-10-12-14-16-18 20-22-24-26-28-30	100	4	67,50

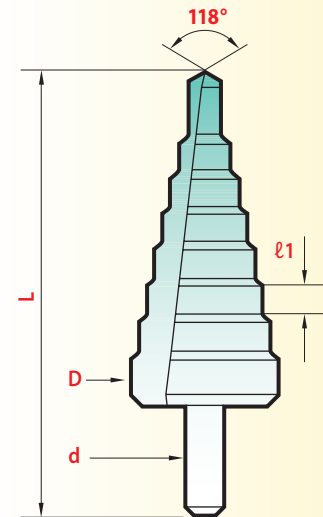
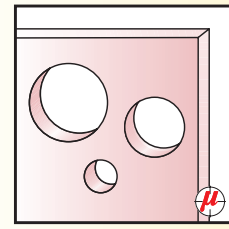

FORET MULTI-ÉTAGES Goujures DROITES

MULTI-STEPS DRILLS STRAIGHT flutes

BROCAS ESCALONADAS Labios RECTO

UTENSILI CONICI A GRADINI Scanalature DIRITTE

Promo-kits



3 MULTI-DIA Ø 12 - 20 - 30
Code 273 € 108,16

MULTI-DIA

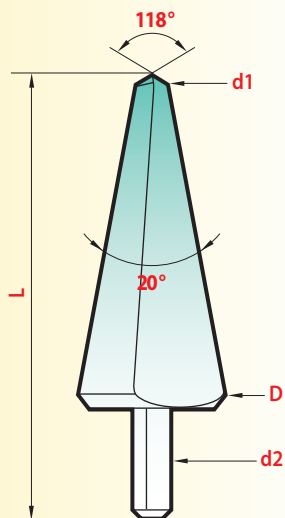
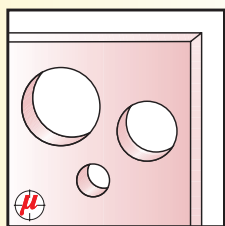

20°

MULTI-DIA

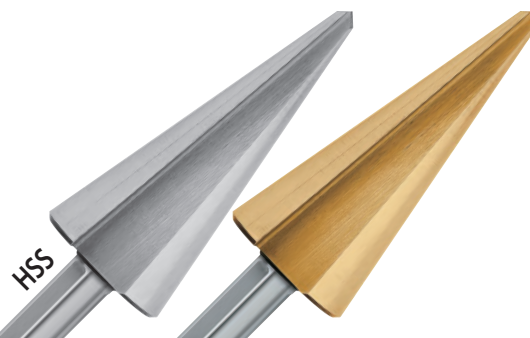

D	d1	d2	L	Classic 272	TiN 2872
14	3	6	62	€ 15,15	€ 18,29
20	6	8	72	23,77	31,35
30	16	10	77	46,50	55,91
30 SL	6	10	94	54,86	64,79
40	25	12	87	82,03	94,57
53	37	12	98	138,98	156,75

FORETS CONIQUES
Pour tôles

CONICAL DRILLS
for sheets

BROCAS CONICAS
Para chapas

UTENSILI CONICI
Per lamiera



Promo-kits

3 MULTI-DIA Ø 14 - 20 - 30 SL

Code **272** € 93,53

Code **2872** € 113,90